

**STEREO PLUS 2**  
**SN / SW-CHASSIS**  
**(50 Hz, 4:3 / 16:9)**

**TV**  
3 / 1999

- Ⓒ **Service manual**
- Ⓓ **Service-Manual**
- Ⓔ **Serviceanvisning**

- Ⓕ **Manuel de service**
- Ⓖ **Manuale di servizio**

**AKAI**

*RTV servis Horvat*

Tel: ++385-31-856-637

Tel/fax: ++385-31-856-139

Mob: 098-788-319

[www.rtv-horvat-dj.hr](http://www.rtv-horvat-dj.hr)

TV 2550-TN  
TV 2550-T Multi  
TV 2551-TN  
TV 2551-TN UK  
TV 2551-TN Multi  
TV 2850-TN  
TV 2850-T Multi  
TV 2851-T Multi

TV 2851-T Multi White  
TV 2852-T  
TV 2852-T Multi  
TV 2852-TN UK  
TV 2881-T Multi  
TV 2881-T Multi UK  
TV 3451-T Multi

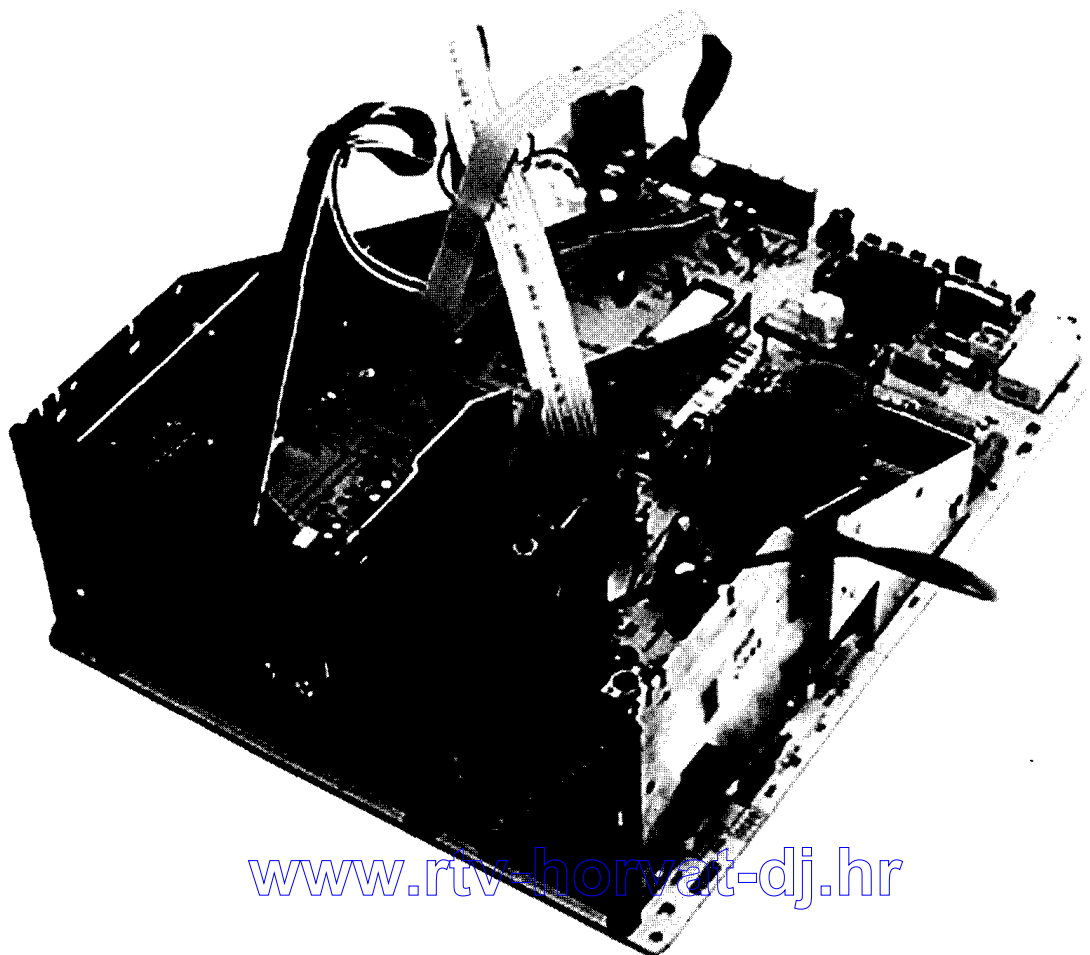

[www.rtv-horvat-dj.hr](http://www.rtv-horvat-dj.hr)

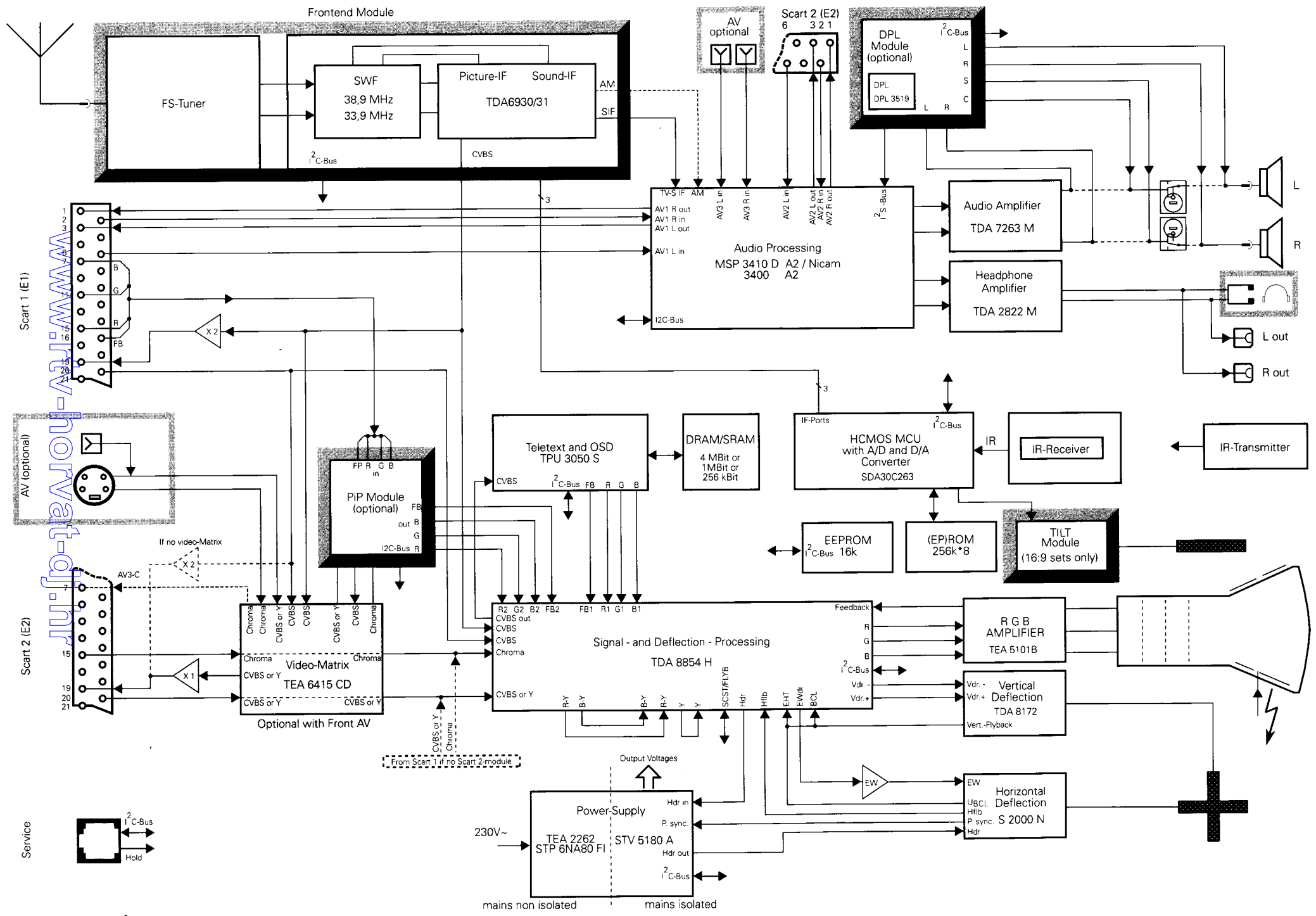

www.irv-norvat-qi.nl

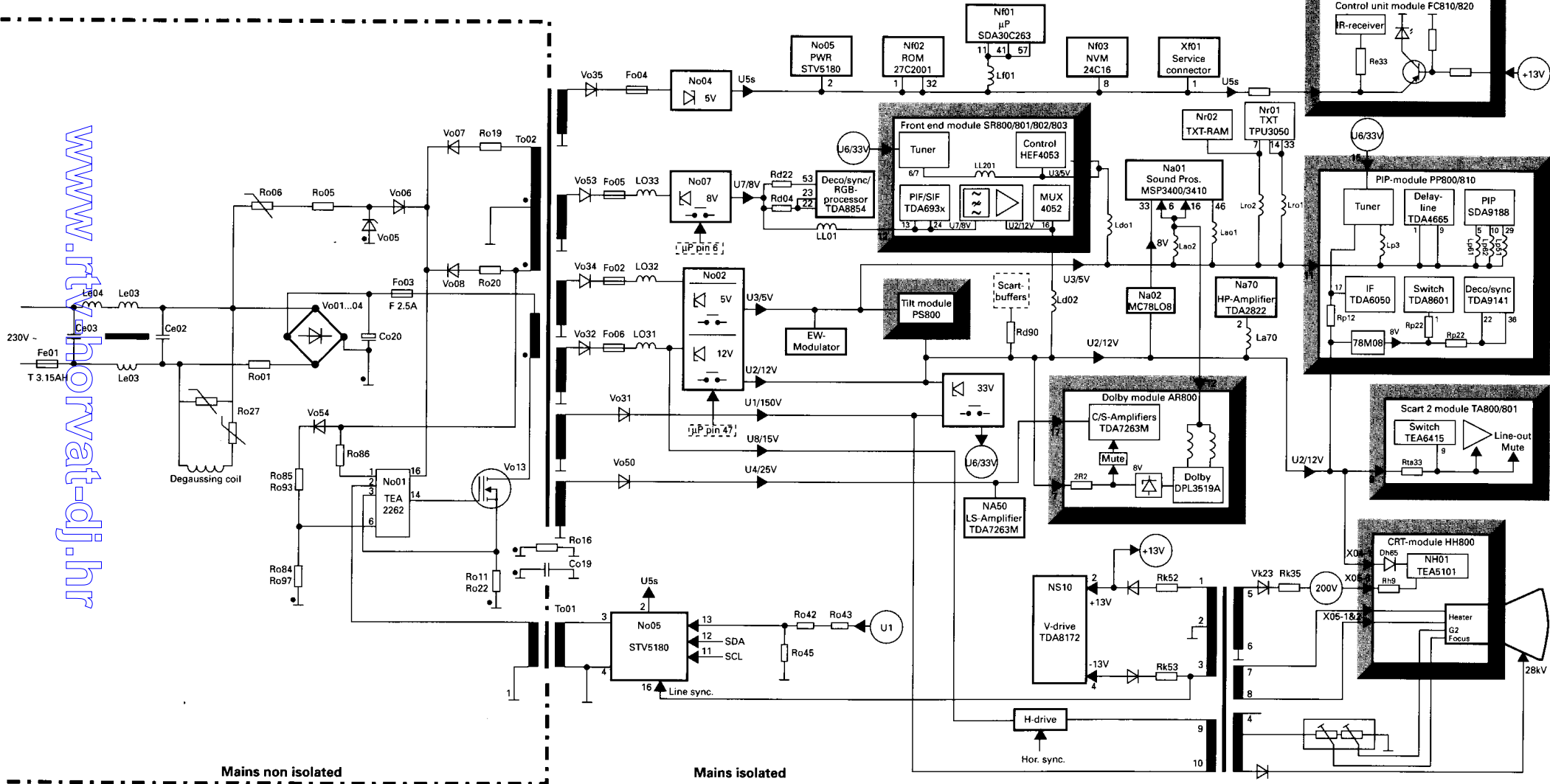

www.rtv-horvat-dj.hr

Mains non isolated

Mains isolated

28kV

## Operating instructions

### Changing the menu language

1. Press the yellow button to select the Vision menu.
2. Press the red button to select the Display set-up menu.
3. Change the menu language with cursor buttons.
4. Press the OK button to store the changes.
5. Press the TV button to exit.

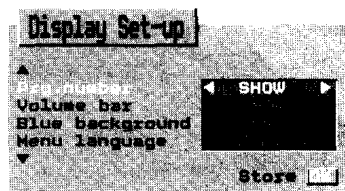

### Manual tuning

1. Select the programme number you want to tune.
2. Press the MENU button.
3. Select "Tuning" with the cursor buttons and press the OK button.
4. Select "Manual tuning" and press the OK button.
5. Select "Channel"-line with the cursor buttons and select the channel you want to watch with 3 digits.
6. Press the OK button to store.
7. Press the TV button to exit.

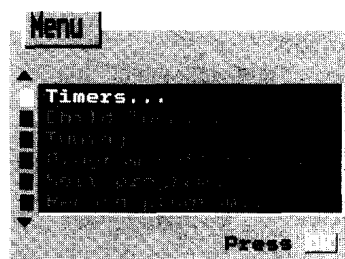

### APSi (Automatic Programming System)

1. Press the MENU button.
2. Select "Tuning" with the cursor buttons and press the OK button.
3. Select "Automatic retuning" and press the OK button.
4. To retune the channels, press the red button.

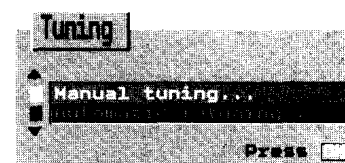

## Service adjustments

### Service mode activation

Service mode can be enabled whenever the receiver is switched ON or is in stand-by mode.

- 1a) If the receiver is switched ON, press the  $\blacktriangleleft$ - (volume minus) button on local control unit and at the same time start entering password: MENU and TV. Release the  $\blacktriangleleft$ - button after the MENU button has been pressed.
  - 1b) If the receiver is in stand-by mode, press the  $\blacktriangleleft$ - button on local control unit and at the same time start entering password: MENU and TV. Release the  $\blacktriangleleft$ - button after the MENU button has been pressed. Switch ON the receiver by pressing the TV button.
2. Activate the service mode by pressing the  $\mathbf{i}$  button and exit the service mode by pressing the TV button.
  3. Disable the service mode by switching off the receiver with the mains switch.

*Note! Service mode activation stays enabled until the receiver is switched off with the mains button.*

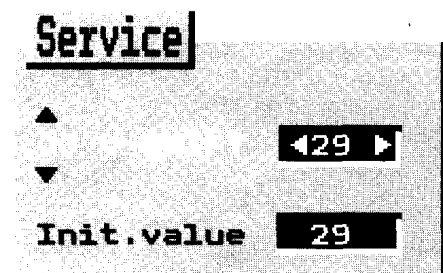

In service mode an adjustment menu is shown on the screen. The adjustment number and name, initializing (bottom) and adjustment (top) values are shown in the menu.

## Initialization of NVRAM

### Initialization of NVRAM

If the NVRAM is replaced, it must be initialized and configured.

*Note! The receiver doesn't start with uninitialized NVRAM, but stays in stand-by mode.*

1. Activate the service mode as described in "Service mode activation".
2. Initialize the NVRAM by entering the key code: BLUE, 2, 5, 4 and OK. Wait approx. 15 seconds and then press the OK button again.
3. Exit the service mode by pressing the TV-button.
4. Start the receiver and tune in one or more TV channels with the "manual tuning" method.

*Note! The channel search doesn't work before the reference adjustments (code 12 and 13) have been made, see page 10.*

5. Enter the service mode again and configure the TV set as described in "Configuration and fault diagnosis". (Check that the automatic configuration results in IIC DEV 1&2, AUTO OPT and IF OPT bytes are corresponding to the actual configuration of the TV set.)
6. Set the manual option bytes (TEXT OPT, HW OPT and SW OPT) to correspond the actual configuration of the TV set.
7. Make all necessary service adjustments (see section "SERVICE ADJUSTMENTS VIA IIC BUS, page 9)

*Note! U1 VALU adjustment must be done first.*

8. Disable the service mode by switching off the receiver with the mains switch.

## Service adjustments

### Configuration and fault diagnosis

The set must be configured after adding or removing any option. By pressing the RED button in service mode, the processor checks the configuration of the TV set and shows the settings on the screen. The configuration can be stored by pressing the OK button.

This feature can also be used in fault diagnosis. If an option bit is not '1' when it should be, the IC (or feature) is either not present or faulty.

*Note! IIC DEV 1, IIC DEV 2, AUTO OPT and IF OPT bytes are configured automatically every time the RED-button is pressed.*

*TEXT OPT, HW OPT and SW OPT bytes must be set manually.*

### Changing the option bytes

1. Select the configuration mode by pressing the RED button in the service mode.

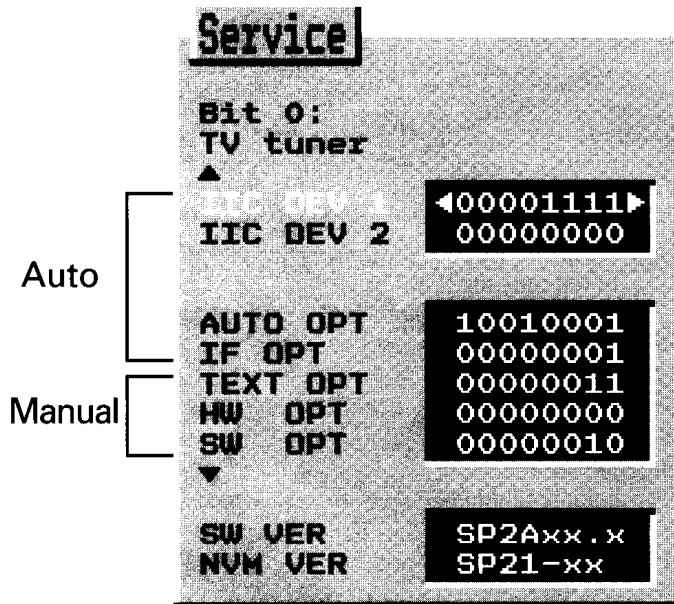

SW VER =  $\mu$ P software version.

NVM VER = NVRAM software version.

2. Select IIC Device byte 1 - 2 or Option byte 1 - 5 with cursor buttons (up/down). The selected byte is shown highlighted.  
The name of a responding bit can be seen by using cursor buttons (left/right).
3. Set / clear the bits with number buttons (0 ... 7).
4. Store the settings by pressing the OK button.
5. Return to the normal service mode by pressing the RED button.

### Option byte description

Bit	Description	Setting	'1'	'0'
7 6 5 4 3 2 1 0				
		<b>IIC DEV 1</b>	<b>00001111</b>	
0	TV tuner 5002PH5		Yes	No
1	Decoder/sync processor TDA8854		Yes	No
2	Teletext processor TPU3050		Yes	No
3	Sound processor MSP34x0		Yes	No
4	Video matrix switch TEA6415		Yes	No
5	PIP processor		Yes	No
6	PIP tuner		Yes	No
7	3D virtual sound processor		Yes	No
		<b>IIC DEV 2</b>	<b>00000000</b>	
5	Power controller STV5180		Yes	No
6	Sound processor MSP3410		Yes	No
7	Reserved for production use		Yes	No
		<b>AUTO OPT</b>	<b>10010001</b>	
0	Scart 2		Yes	No
1	16:9 picture tube		Yes	No
3	Text memory 4 Mb DRAM		Yes	No
4	Text memory 1 Mb SRAM		Yes	No
5	Text memory 256 kb SRAM		Yes	No
6	Tilt adjustment		Yes	No
7	NICAM identification enabled		Yes	No
		<b>IF OPT</b>	<b>00000001</b>	
0	B/G system in IF		Yes	No
1	I system in IF		Yes	No
2	D/K system in IF		Yes	No
3, 4	L/L' system in IF		Yes	No
5	HEF4094B in IF		Yes	No
		<b>TEXT OPT</b>	<b>00000011</b>	
1	FLOF function enabled		Yes	No
7,6,5	Text character set selected			
	000 = West Europe / Czech			
	001 = East Europe			
	010 = West Europe / USA			
	011 = West Europe / Turkish			
	100 = East Europe 2			
		<b>HW OPT</b>	<b>00000000</b>	
0	A/V connector installed		Yes	No
1	SVHS input in AV		Yes	No
2	3.58 MHz xtal installed		Yes	No
		<b>SW OPT</b>	<b>00000010</b>	
1	Carrier mute enabled		Yes	No
2	Stand-by prevent		Yes	No
3	Autostart enabled (Special use only!)		Yes	No
4	Pal + helper blanking 4:3		Yes	No
5	E1 FB enabled (USER)		Yes	No
7	Hotel TV enabled		Yes	No
		<b>SW VER</b>	<b>SP2Axx.x</b>	
SW VER = $\mu$ P software version				
		<b>NVM VER</b>	<b>SP21-xx</b>	
NVM VER = NVRAM software version				

## Service adjustments via IIC bus

### Remote control buttons in service mode

When the receiver is in the service mode you can select normal TV mode by pressing the TV button and return to the service mode by pressing the i button.

Number and cursor buttons are used for service adjustments. The OK button stores the settings. The yellow button hides/shows the service menu to simplify the picture adjustments.

### Making adjustments for different picture formats

Make all adjustments with PAL signal unless otherwise mentioned. Make 4:3 set adjustments with normal 4:3(CLASSIC) picture format and 16:9 set adjustments with wide picture format. Then make the necessary adjustments with other picture formats/signals. The required adjustments are shown in the table below.

*Note! Check the configuration of the TV set before making the adjustments and make only the necessary adjustments.*

### Making a service adjustment

1. Give a two digit code which determines an adjustment (e.g. 00 = vertical shift, see the following tables) with the number buttons. You can also select the adjustment with cursor buttons (up-/down).

*Note! Power supply and UG2 adjustments must be done before picture geometry adjustments.*

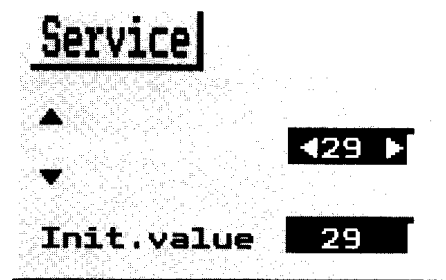

2. Adjust with the cursor buttons (left/right).

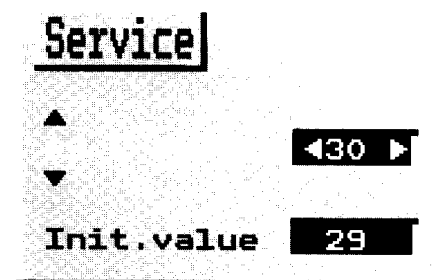

3. Store the new value by pressing the OK button.

### Note!

- To avoid incomplete adjustments store each adjustment in the memory immediately after an adjustment has been made.
- If an adjustment has to be made separately for different picture format/signal, select first the normal mode by pressing the TV button and select then the desired picture format/signal. Return to service mode by pressing the i button.

### Picture geometry adjustments

Adjustment	Code	OSD name	4:3 sets				16:9 sets				RGB	60 Hz signal	Note!	
			CLASSIC (4:3)	MOVIE (4:3)	MOVIE LIFTED (4:3)	WIDE (4:3)	CLASSIC (16:9)	IDEAL (16:9)	FULL (16:9)	FULL LIFTED (16:9)				WIDE (16:9)
Vertical off-centre shift	00	V-SHIFT	X											Center line
Vertical amplitude	01	V-AMPL.	X									X		Adjust upper side
Vertical slope	02	V SLOPE	X										X	Adjust lower part
Vertical S-correction	03	S-CORR.	X				X						X	
Vertical zoom	04	VER ZOOM	(X)	X		X	X	X					(X)	Recommended to use init value first!
Vertical scrolling	05	V SCROLL	(X)			X				X			(X)	Recommended to use init value first!
Width	06	WIDTH	X	X			X						X	
Horizontal shift deflection	07	H-SHIFT	X									X	X	
Parabola	08	PARABOLA	X										X	
Corner	09	CORNER	X										X	
Trapezium	10	TRAPEZ	X										X	

## Service adjustments

### O Power supply block

#### Supply voltage and protection circuit

1. Set the brightness and the contrast to the normal level. Connect a universal voltmeter to the cathode of Vo31.
2. Adjust the U1 voltage with U1 VALU in the service mode. (The voltage depends on the picture tube type, refer to the section "Variable components").
3. Check the over-current protection after making any service operations in the primary circuit of the power supply. Switch the set to stand-by mode. Short circuit the cathode of Vo50 to the ground and keep the short circuit connected. When the over-current protection works correctly, the power supply stops permanently. Switch off the receiver by pressing the mains button. Remove the short circuit and then switch on the receiver by pressing the mains button.

#### AFC adjustments (code 12 and 13)

- 1) The right value is found when while changing the value, the AFC display changes from 0 to 1.
- 2) Adjust with a channel sent with L'-standard. Needed only in multinorm TV sets.

*Note! Use the right channel frequency.  
Tune the channel with "manual tuning method"  
(see page 7).*

### K Horizontal deflection block

#### Focusing

Set the brightness and the contrast to the normal level. Use the crosshatch pattern and adjust the picture for optimum resolution.

#### (Screen grid voltage) Ug2 voltage

1. Set the brightness and the colour saturation to the normal level and the contrast to minimum.
2. At the end of the vertical blanking, there is a black current measurement pulse (clamp pulse) at pin 9, 12 and 15 of NH01. Use an oscilloscope and find the output stage with the highest cut-off (i.e. the highest voltage during the black current measurement pulse).
3. Adjust the voltage of the upper clamp pulse to +150 V with Ug2 (see figure).

*Note! Adjust the voltage with a clamp pulse.*

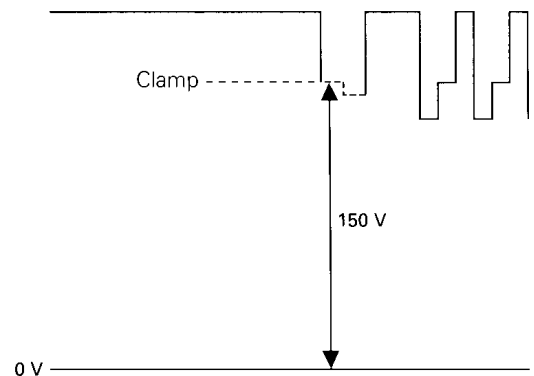

### Other adjustments

Adjustment	Code	OSD name	RF OTHER	RF SECAM L	SCART	Note!
Luma delay	11	Y-DELAY	X	X	X	
IF 33.9 reference voltage for AFC	12	REF 339				1), 2)
IF 38.9 reference voltage for AFC	13	REF 389				1)
STV5180 DAC value for U1 control	14	U1 VALU				Must be done before other adjustments!
Red gain	15	R GAIN				
Green gain	16	G GAIN				
Blue gain	17	B GAIN				

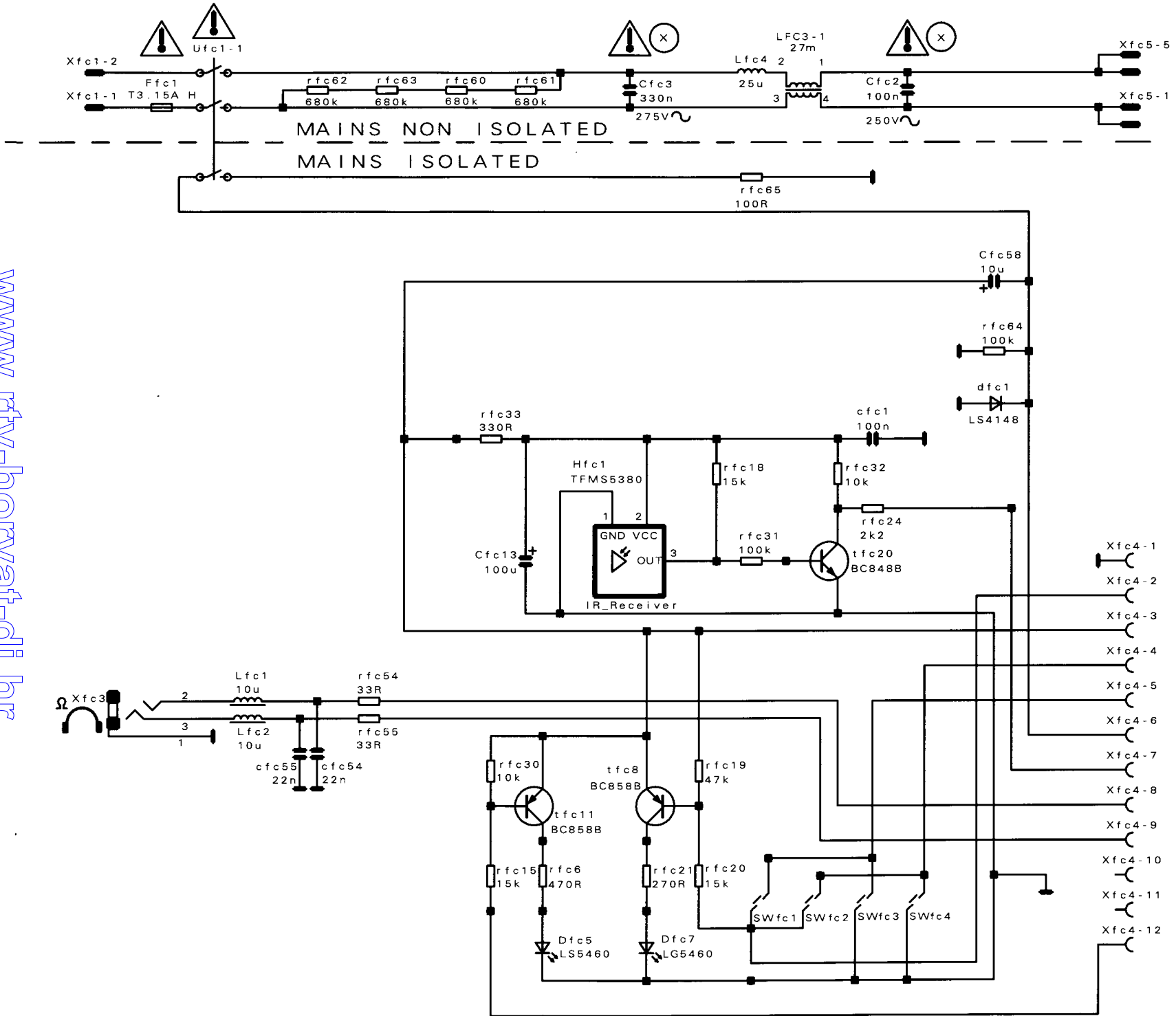



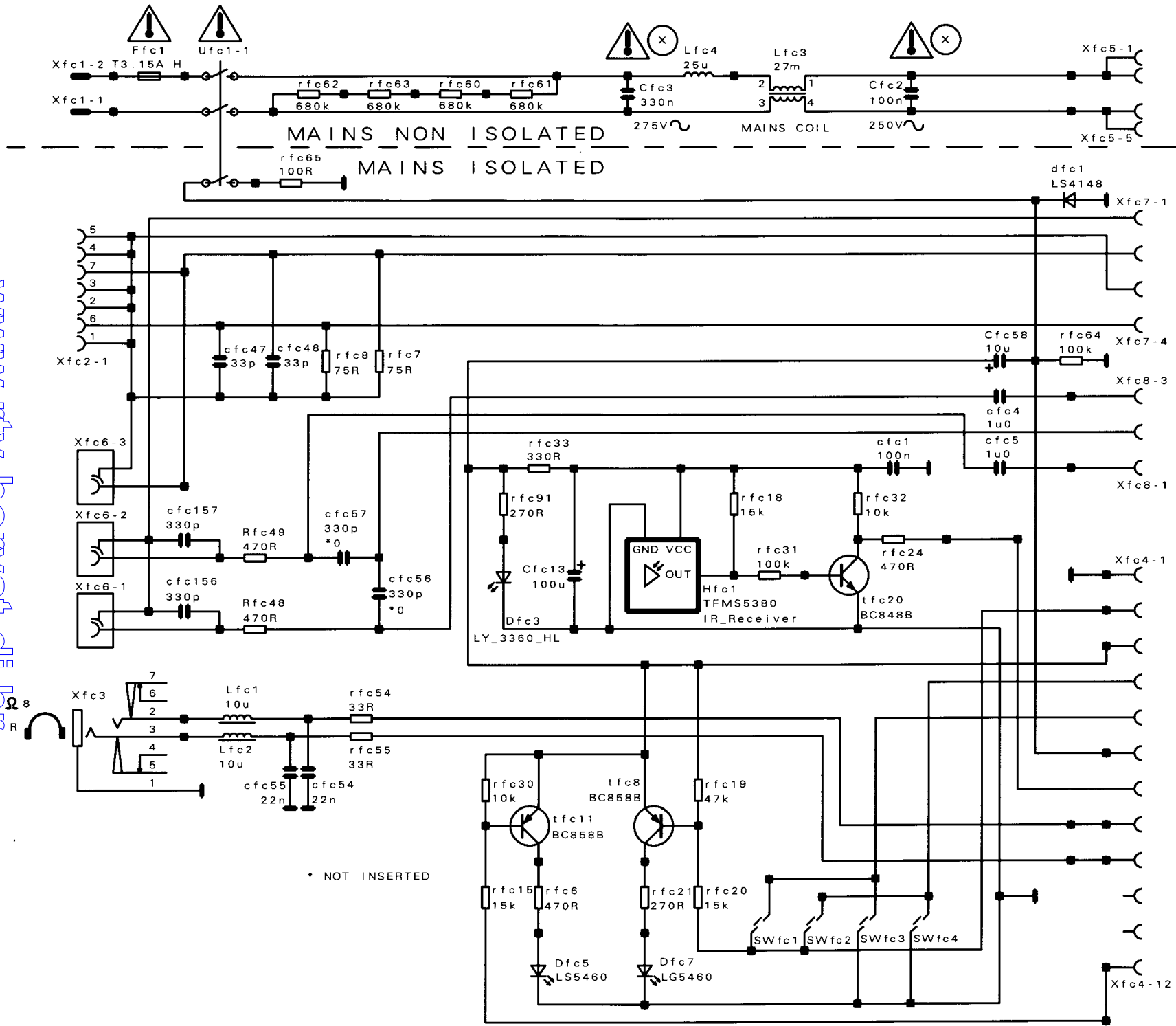

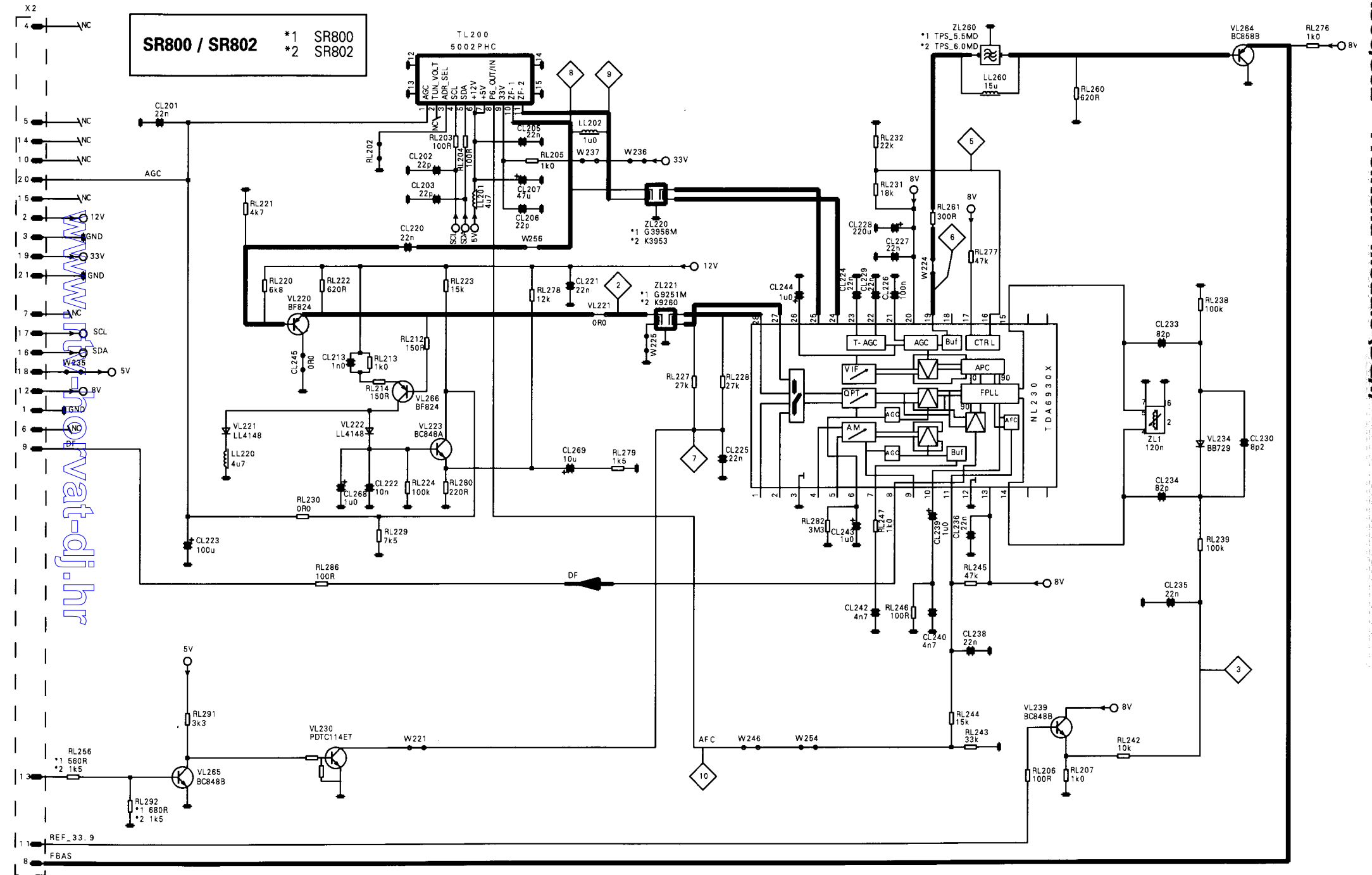

SR800 / SR802 \*1 SR800 \*2 SR802

www.fv-at-dj.hr

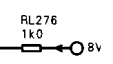
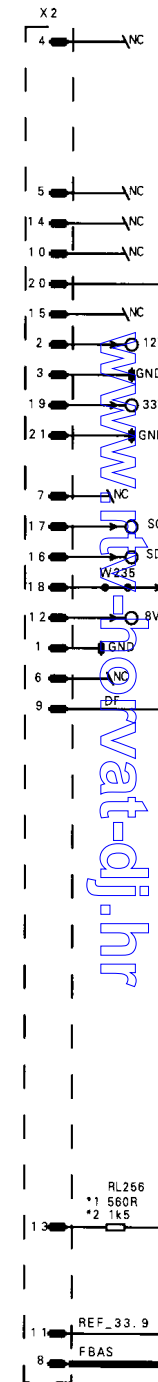

ZL260 \*1 TPS\_5.5MD \*2 TPS\_6.0MD

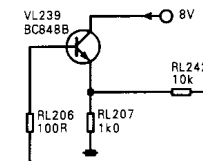
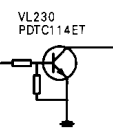
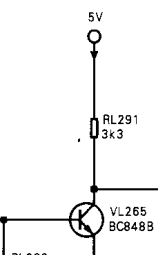

SR801 / SR803 \*1 SR801  
\*2 SR803

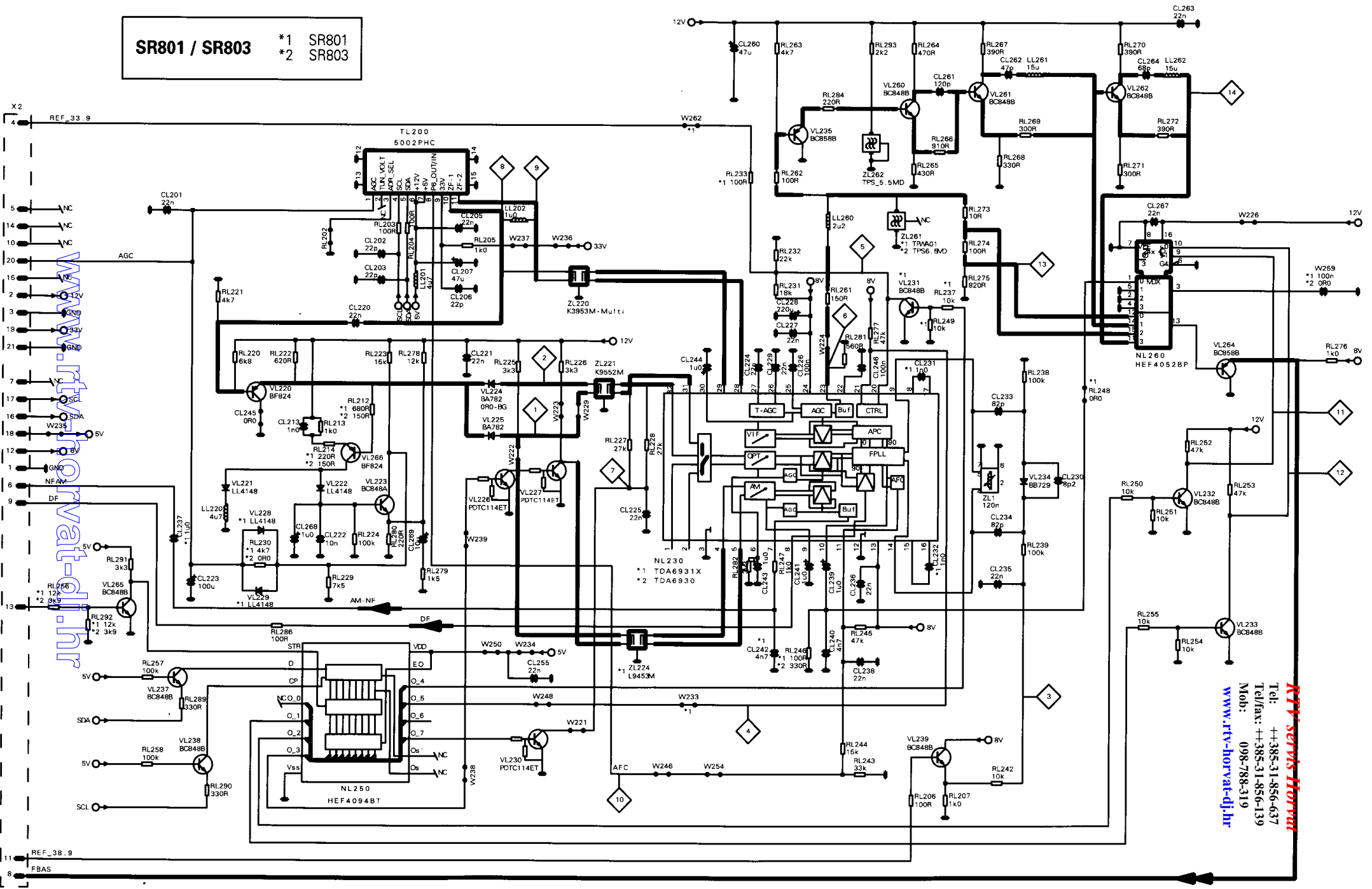

RTV servis Horvat  
 Tel: ++385-31-856-637  
 Tel/fax: ++385-31-856-139  
 Mob: 098-788-319  
 www.rtv-horvat-dj.hr

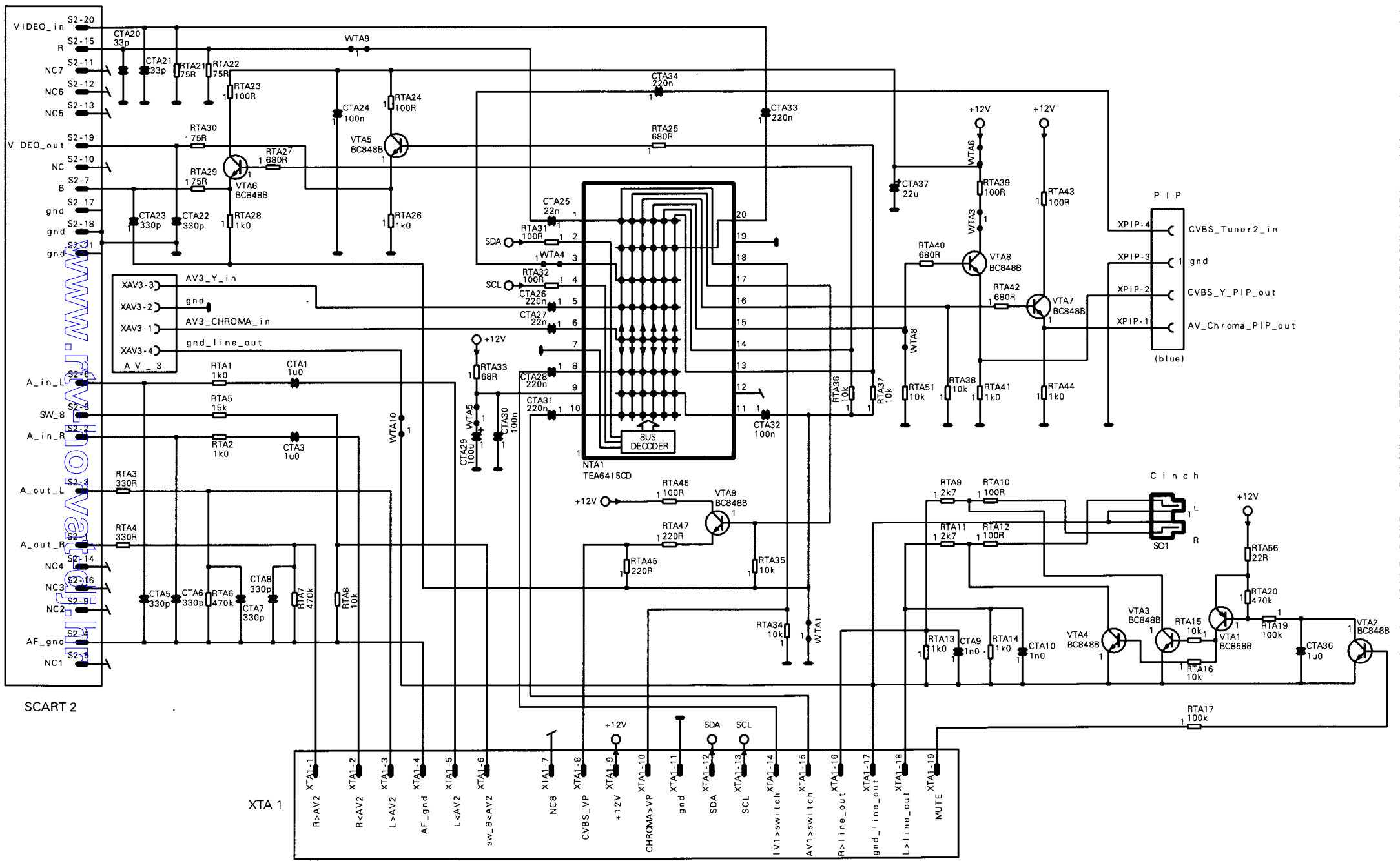

www.inovatech.it

SCART 2

XTA 1

Cinch

S O1

PIP

XPIP-4 CVBS\_Tuner2\_in  
XPIP-3 gnd  
XPIP-2 CVBS\_Y\_PIP\_out  
XPIP-1 AV\_Chroma\_PIP\_out  
(blue)

VIDEO\_in S2-20  
S2-15  
R NC7 S2-11  
NC6 S2-12  
NC5 S2-13  
VIDEO\_out S2-19  
S2-10  
NC S2-7  
B S2-17  
gnd S2-18  
gnd S2-21  
XAV3-3 AV3\_Y\_in  
XAV3-2 gnd  
XAV3-1 AV3\_CHROMA\_in  
XAV3-4 gnd\_line\_out  
A V \_ 3  
A\_in\_ S2-6  
SW\_8 S2-8  
A\_in\_R S2-2  
A\_out\_L S2-3  
A\_out\_R S2-1  
NC4 S2-14  
NC3 S2-16  
NC2 S2-9  
AF\_gnd S2-4  
NC1 S2-5

XTA1-1 R>AV2  
XTA1-2 R<AV2  
XTA1-3 L>AV2  
XTA1-4 AF\_gnd  
XTA1-5 L<AV2  
XTA1-6 sw\_8<AV2  
NC8  
XTA1-8 CVBS\_VP  
XTA1-9 +12V  
XTA1-10 CHROMA>VP  
XTA1-11 gnd  
XTA1-12 SDA  
XTA1-13 SCL  
XTA1-14 TV1>switch  
XTA1-15 AV1>switch  
XTA1-16 R>line\_out  
XTA1-17 gnd\_line\_out  
XTA1-18 L>line\_out  
XTA1-19 MUJTE

L  
R

S

R

L

R

+12V

+12V

+12V

+12V

+12V

+12V

+12V

+12V

+12V

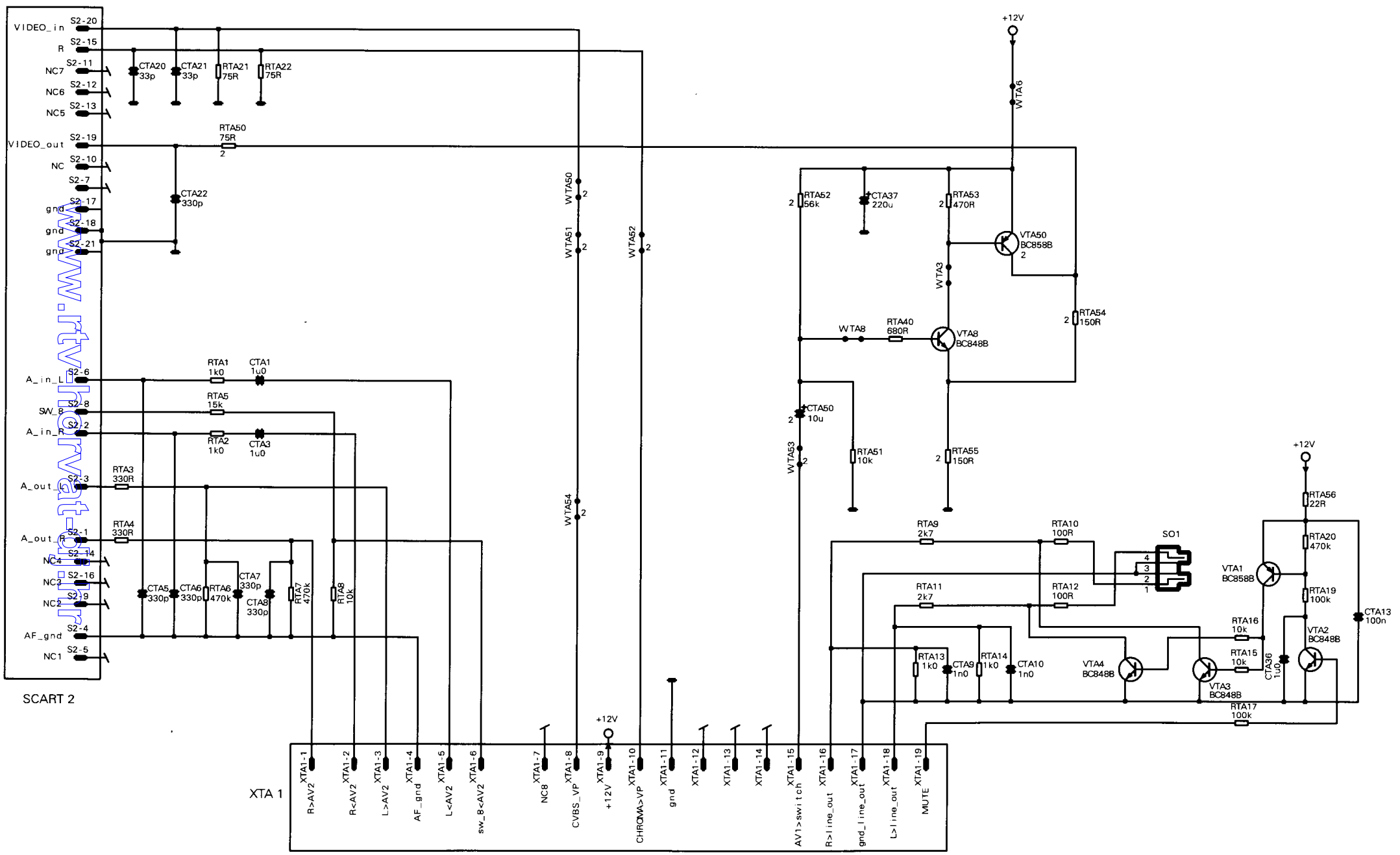

SCART 2

XTA 1

www.rtv-normat.com

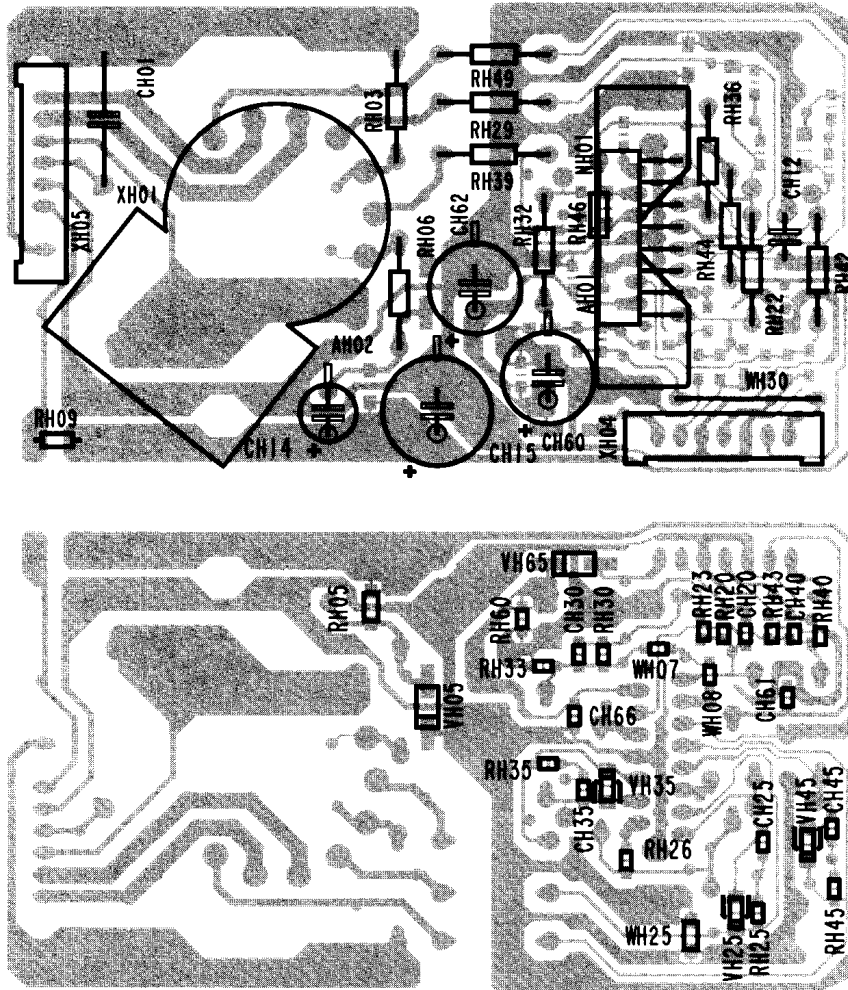

PS800 Picture tilt module

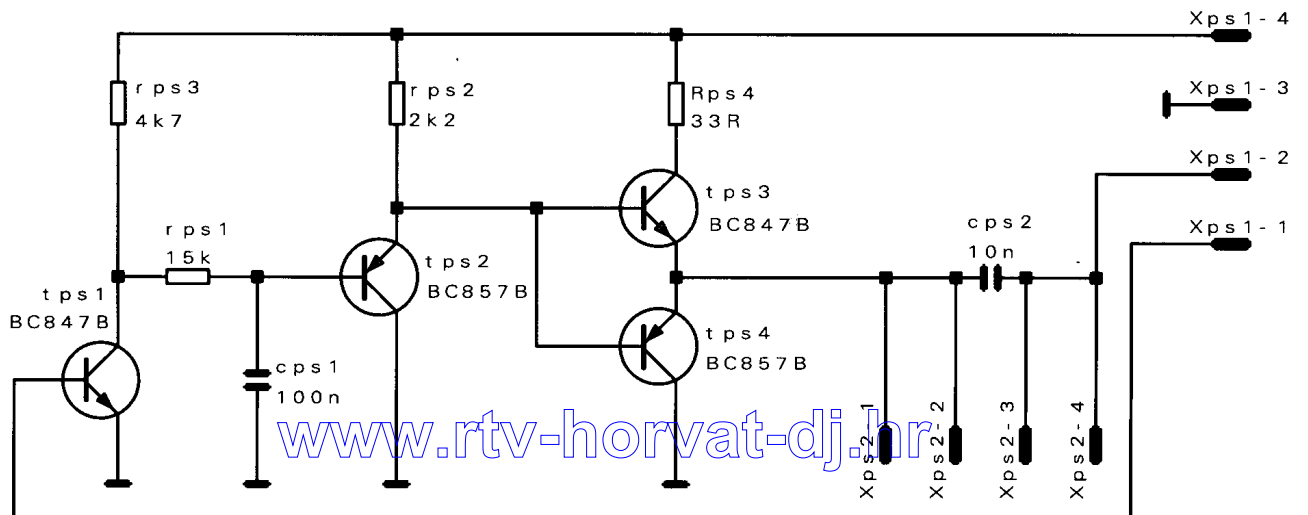
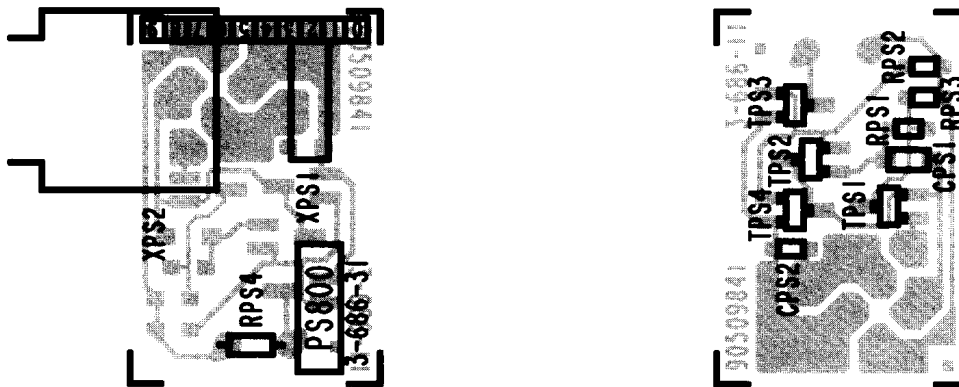

Picture tube	Vi A59EAS 13X01		Vi A59EHJ 43X01		Vi A66EAS 13X01		Vi A66EHJ 43X01		Vi A66EHJ 43X01		Vi W66EHU 013X101		Vi A80AEJ 33X04	
Chassis	C*AB1A*		B*BC3A*		C*AE1A*		B*AF2A*		B*BF3A*		C*BJ7A*		B*AM3A*	
PW-block	PW-8B0		PW-8C0		PW-8E0		PW-8F0		PW-8F0		PW-8J0		PW-8M0	
RF-block	RF-801		RF-803		RF-801		RF-802		RF-803		RF-807		RF-803	
RA 42,43			3142 5852	100R			3142 5852	100R	3142 5852	100R	3142 5852	100R	3142 5852	100R
RA 65,66			3142 6211	2K0			3142 6211	2K0	3142 6211	2K0	3142 6211	2K0	3142 6211	2K0
RD 59	3163 0092	390K	3154 8967	270K	3163 0092	390K	3154 8967	270K	3154 8967	270K	3163 0045	220K	3154 8967	270K
RE 07,08			3142 5669	75R					3142 5669	75R			3142 5669	75R
RE 48,49			3142 5817	470R					3142 5817	470R			3142 5817	470R
RE 50,51			3142 5848	470K					3142 5848	470K			3142 5848	470K
RK 51					3154 8729	82K	3154 8729	82K	3154 8729	82K	3154 8729	82K	3144 0013	61K9
RS 12	3143 0281	2R15 0W6	3143 0281	2R15 0W6	3143 0281	2R15 0W6	3143 0281	2R15 0W6	3143 0281	2R15 0W6	3143 0301	3R0 0W6	3143 0281	2R15
RS 34	3143 0281	2R15 0W6	3143 0281	2R15 0W6	3143 0281	2R15 0W6	3143 0281	2R15 0W6	3143 0281	2R15 0W6	3143 0301	3R0 0W6	3143 0281	2R15
CA 20,21,40,41			3212 5517	330p			3212 5517	330p	3212 5517	330p	3212 5517	330p	3212 5517	330p
CA 42,43			3422 3250	22μ / 16V			3422 3250	22μ / 16V	3422 3250	22μ / 16V	3422 3250	22μ / 16V	3422 3250	22μ / 16V
CA 58,59	3422 0551	470μ / 16V	3455 0001	1000μ / 16V	3422 0551	470μ / 16V	3455 0001	1000μ / 16V	3455 0001	1000μ / 16V	3455 0001	1000μ / 16V	3455 0001	1000μ / 16V
CE 35,36			3212 5517	330p					3212 5517	330p	3212 5517	330p	3212 5517	330p
CE 60,61			3454 0022	1μ0 / 63V					3454 0022	1μ0 / 63V			3454 0022	1μ0 / 63V
CE 156,157			3212 5517	330p					3212 5517	330p			3212 5517	330p
CK 11	3324 0835	27n 400V	3324 0835	27n 400V	3324 0835	27n 400V	3324 0835	27n 400V	3324 0835	27n 400V	3325 0915	22n	3324 0835	27n 400V
CK 13	3348 0013	400n 400V	3348 0011	300n 400V	3348 0013	400n 400V	3348 0011	300n 400V	3348 0011	300n 400V	3348 0011	300n 400V	3348 0011	300n 400V
CK60	3312 0948	1μ5 63V	3312 0948	1μ5 63V	3312 0948	1μ5 63V	3312 0948	1μ5 63V	3312 0948	1μ5 63V	3338 0021	3μ3 100V	3312 0948	1μ5 63V
NR 02			3786 0042	IC SRAM					3786 0042	IC SRAM	3786 0042	IC SRAM		
NR 03	3786 0025	IC SRAM			3786 0025	IC SRAM	3786 0025	IC SRAM					3786 0025	IC SRAM
LA 04,05			4562 0055	5,6μH B82144			4562 0055	5,6μH B82144	4562 0055	5,6μH B82144	4562 0055	5,6μH B82144	4562 0055	5,6μH B82144
LK 60	4538 0006	490μH	4538 0006	490μH	4538 0006	490μH	4538 0006	490μH	4538 0006	490μH	4538 0025	590μH	4538 0006	490μH
W 42											Jumper	10mm		
W 72			Jumper	8,75 mm			Jumper	8,75 mm	Jumper	8,75 mm	Jumper	8,75 mm	Jumper	8,75 mm
W 77			Jumper	10,0 mm			Jumper	10,0 mm	Jumper	10,0 mm	Jumper	10,0 mm	Jumper	10,0 mm
WA 23,38,39			Jumper	15,0 mm			Jumper	15,0 mm	Jumper	15,0 mm	Jumper	15,0 mm	Jumper	15,0 mm
WA 24			Jumper	20,0 mm			Jumper	20,0 mm	Jumper	20,0 mm	Jumper	20,0 mm	Jumper	20,0 mm
WA 52,59			3142 5802	0R			3142 5802	0R	3142 5802	0R	3142 5802	0R	3142 5802	0R
WA 53,55	3142 5802	0R			3142 5802	0R								
WD 51	Jumper	12,5 mm			Jumper	12,5 mm								
WD 61	3142 5601	0R			3142 5601	0R								
WW 01,02			Jumper	10,0 mm			Jumper	10,0 mm	Jumper	10,0 mm	Jumper	10,0 mm	Jumper	10,0 mm
Rear plate	8440 0680		8440 0920		8440 0680		8440 0920		8440 0920		8440 0920		8440 0920	
PS800 module											6913 7137	PS800		
TA80x module			6913 7138	TA800			6913 7141	TA801	6913 7138	TA800	6913 7138	TA800	6913 7138	TA800
U1- voltage	150V		150V		150V		150V		150V		150V		150V	

www.ovat-ol.hr

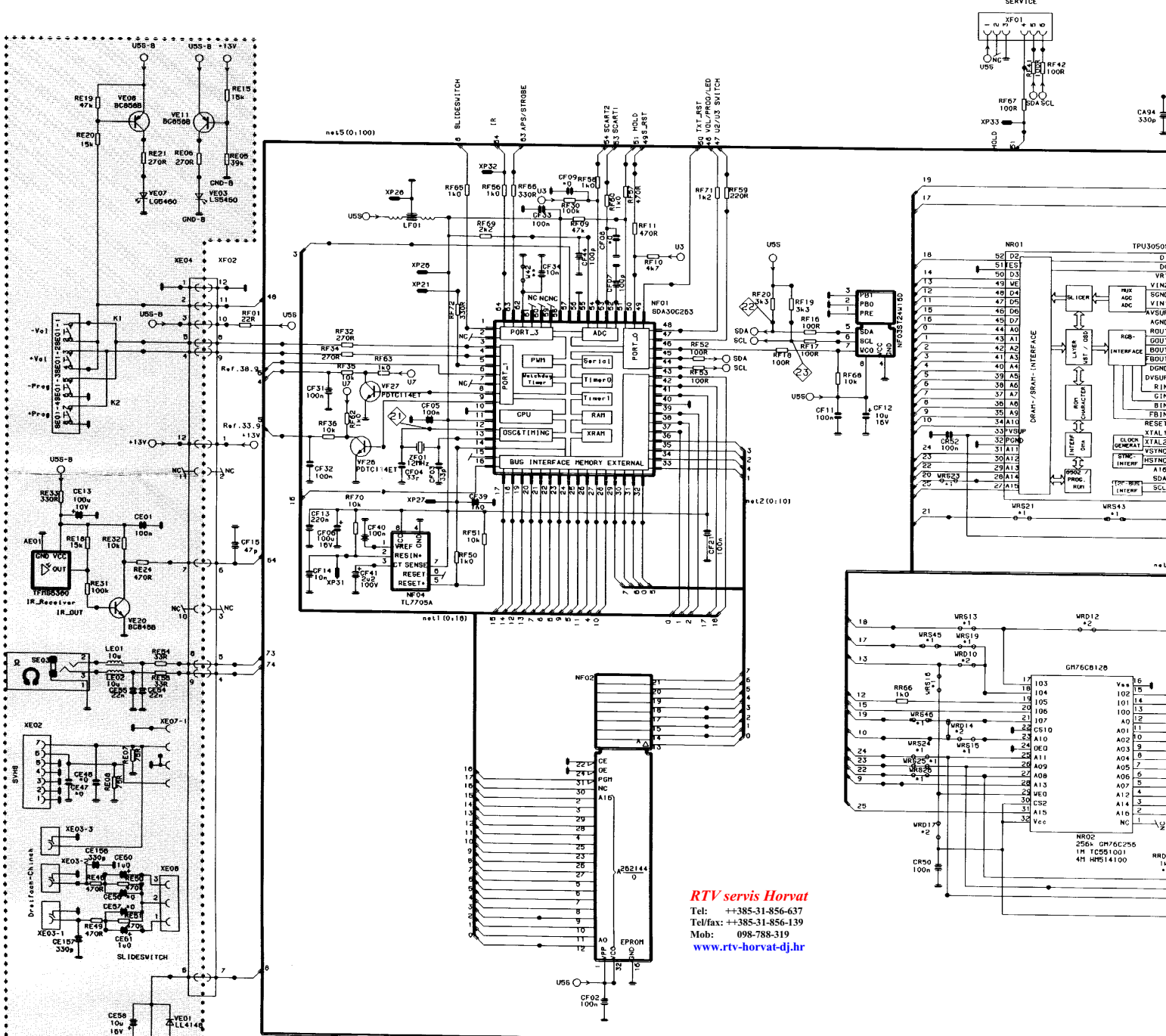

**RTV servis Horvat**  
 Tel: ++385-31-856-637  
 Tel/fax: ++385-31-856-139  
 Mob: 098-788-319  
[www.rtv-horvat-dj.hr](http://www.rtv-horvat-dj.hr)

NETZGETRENNT/MAINS-INSULATED  
 NETZVERBUNDEN/MAINS-CONNECTED

ONLY FOR PUSH THROUGH  
 VERSIONS FC80B

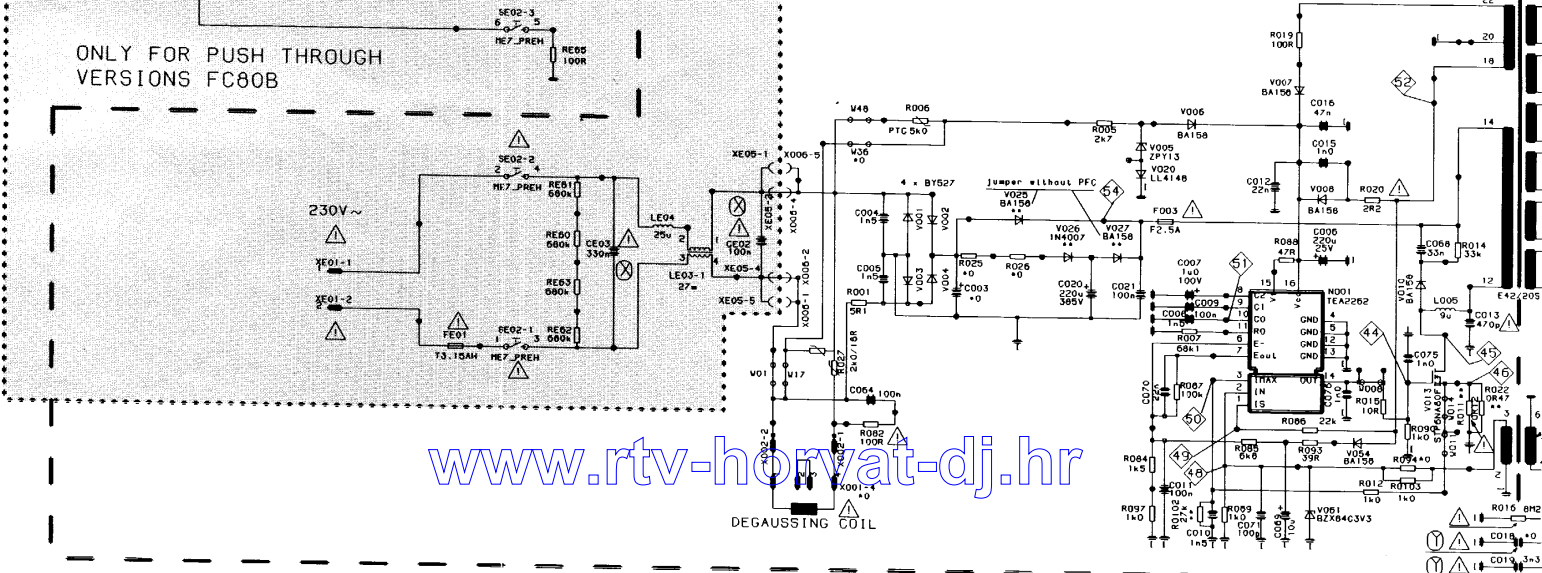

[www.rtv-horvat-dj.hr](http://www.rtv-horvat-dj.hr)

DEGAUSSING COIL



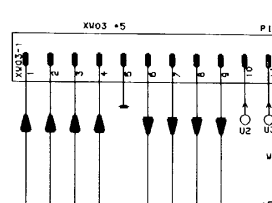
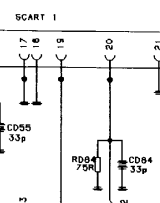
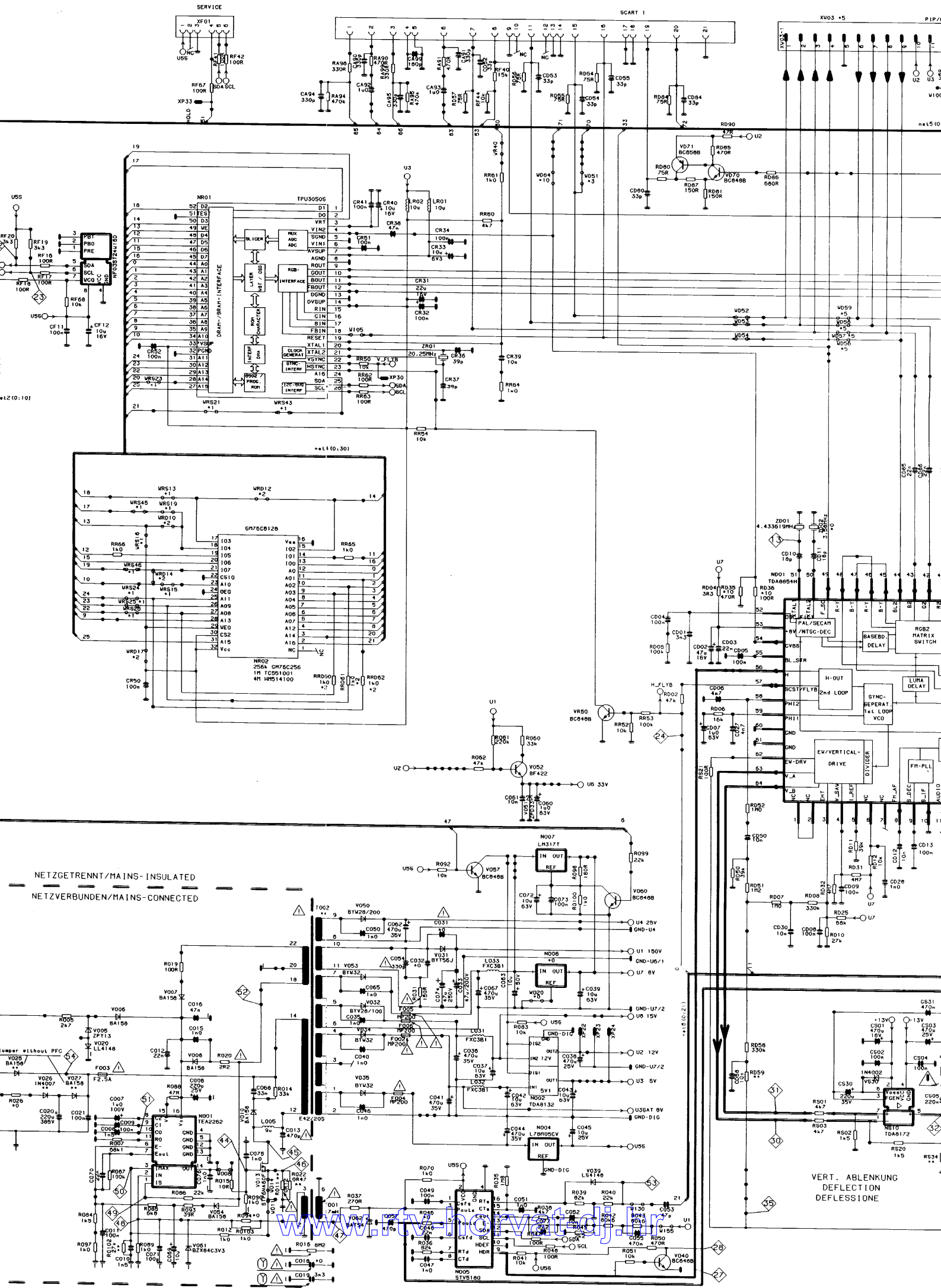

NETZGETRENNT/MAINS-INSULATED  
NETZVERBUNDEN/MAINS-CONNECTED

VERT. ABLENKUNG  
DEFLECTION  
DEFLECTION

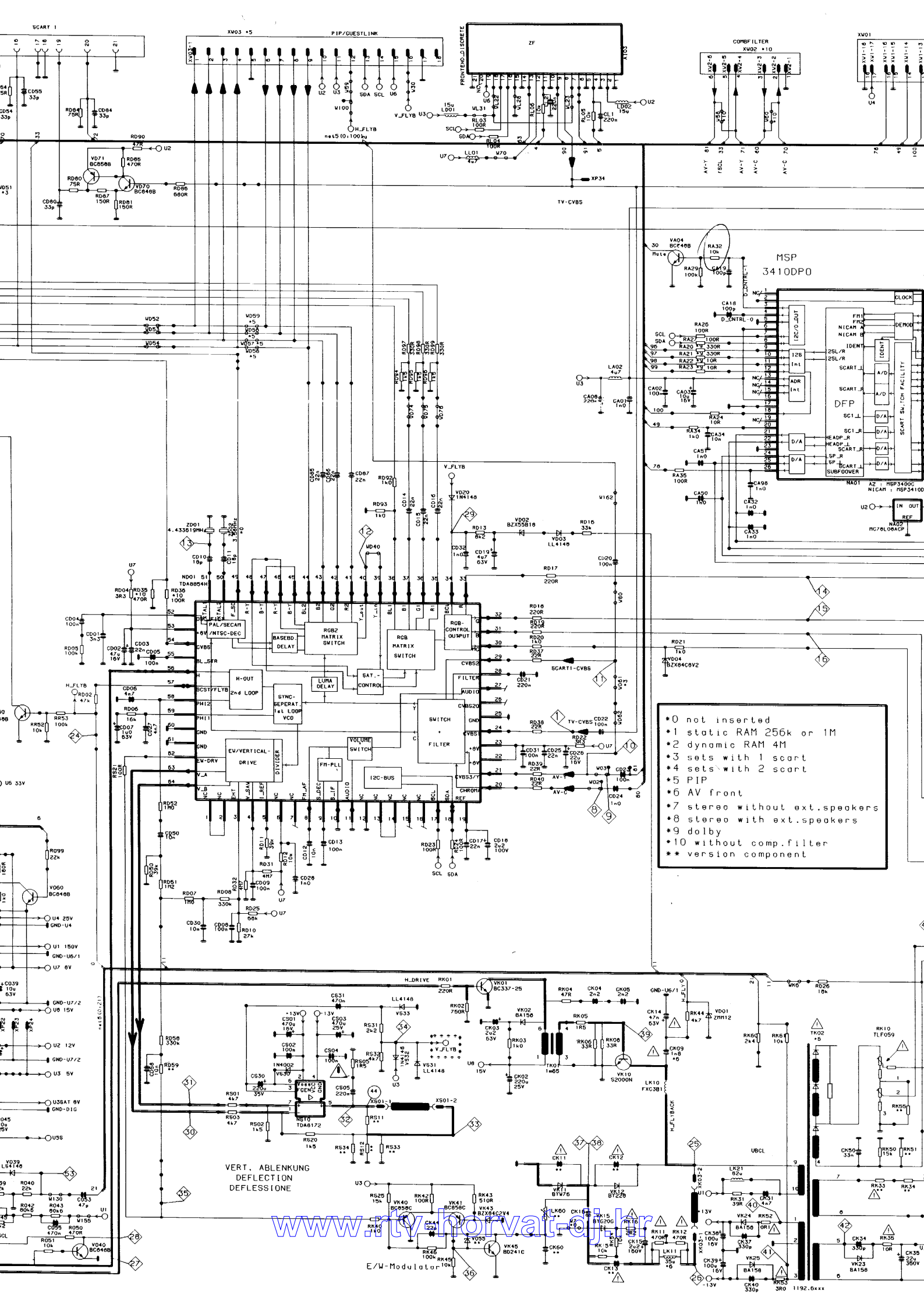

- \* 0 not inserted
- \* 1 static RAM 256k or 1M
- \* 2 dynamic RAM 4M
- \* 3 sets with 1 scart
- \* 4 sets with 2 scart
- \* 5 PIP
- \* 6 AV front
- \* 7 stereo without ext. speakers
- \* 8 stereo with ext. speakers
- \* 9 dolby
- \* 10 without comp. filter
- \*\* version component

www.tv-horvat-dj.hr

E/W-Modulator

VERT. ABLENKUNG  
DEFLECTION  
DEFLESSIONE

M5P  
3410DPO

XW03 \*5

PIP/GUESTLINK

PROV. FELD. DISCRETE

ZF

XW01

COMB FILTER  
XW02 \*10

SCART I

TV-CVBS

VA04 BC49B

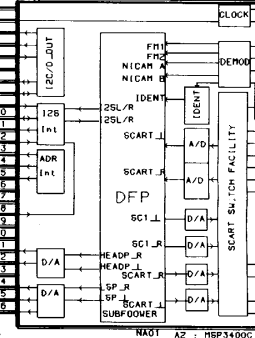

- \* 0 not inserted
- \* 1 static RAM 256k or 1M
- \* 2 dynamic RAM 4M
- \* 3 sets with 1 scart
- \* 4 sets with 2 scart
- \* 5 PIP
- \* 6 AV front
- \* 7 stereo without ext. speakers
- \* 8 stereo with ext. speakers
- \* 9 dolby
- \* 10 without comp. filter
- \*\* version component

www.tv-horvat-dj.hr

E/W-Modulator

VERT. ABLENKUNG  
DEFLECTION  
DEFLESSIONE

M5P  
3410DPO

XW03 \*5

PIP/GUESTLINK

PROV. FELD. DISCRETE

ZF

XW01

COMB FILTER  
XW02 \*10

SCART I

TV-CVBS

VA04 BC49B

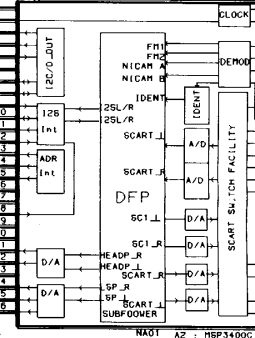

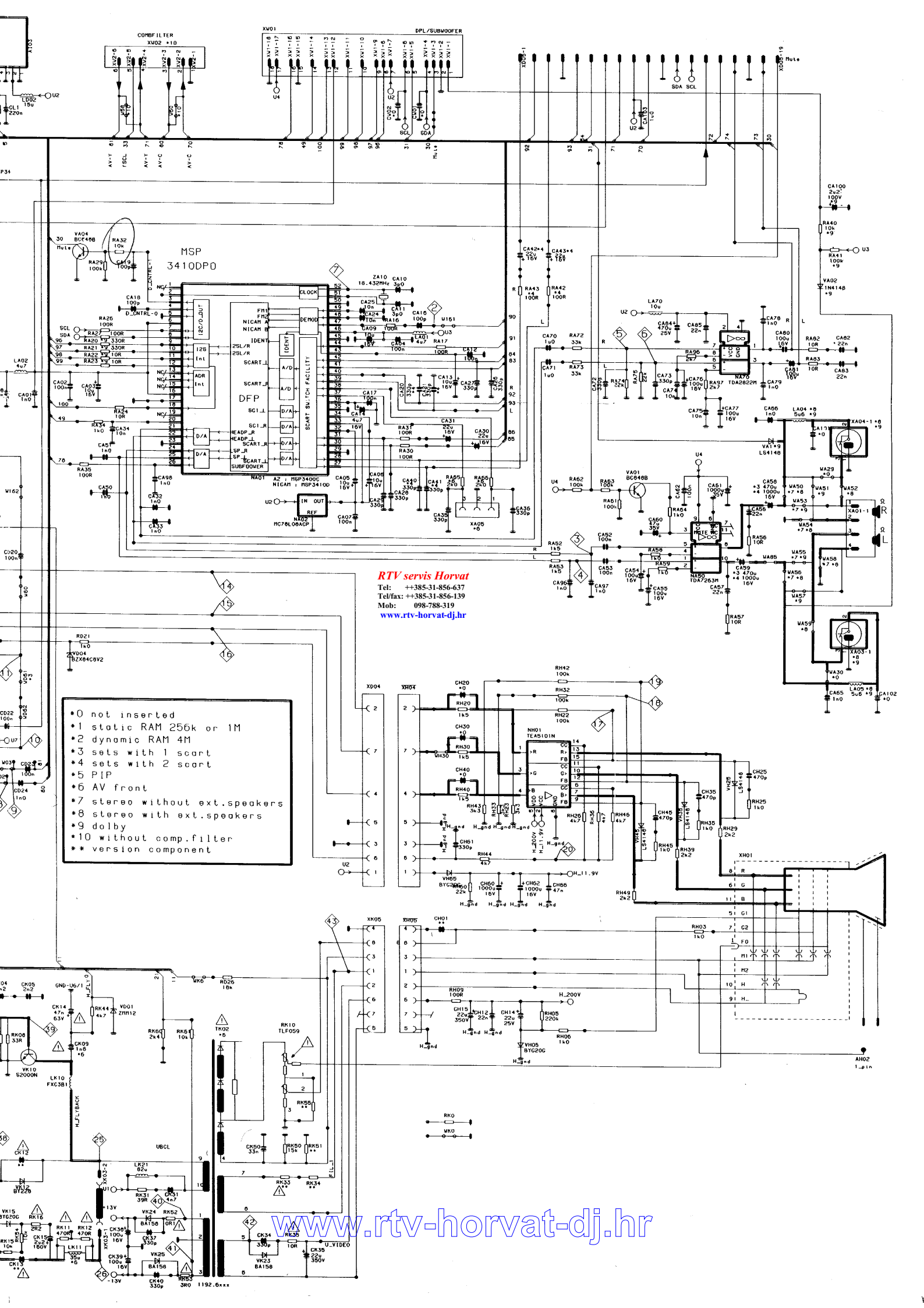

MSP  
3410DPD

**RTV servis Horvat**  
 Tel: ++385-31-856-637  
 Tel/fax: ++385-31-856-139  
 Mob: 098-788-319  
[www.rtv-horvat-dj.hr](http://www.rtv-horvat-dj.hr)

- \*0 not inserted
- \*1 static RAM 256k or 1M
- \*2 dynamic RAM 4M
- \*3 sets with 1 scart
- \*4 sets with 2 scart
- \*5 PIP
- \*6 AV front
- \*7 stereo without ext. speakers
- \*8 stereo with ext. speakers
- \*9 dolby
- \*10 without comp. filter
- \*\* version component

[www.rtv-horvat-dj.hr](http://www.rtv-horvat-dj.hr)

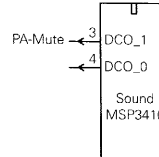
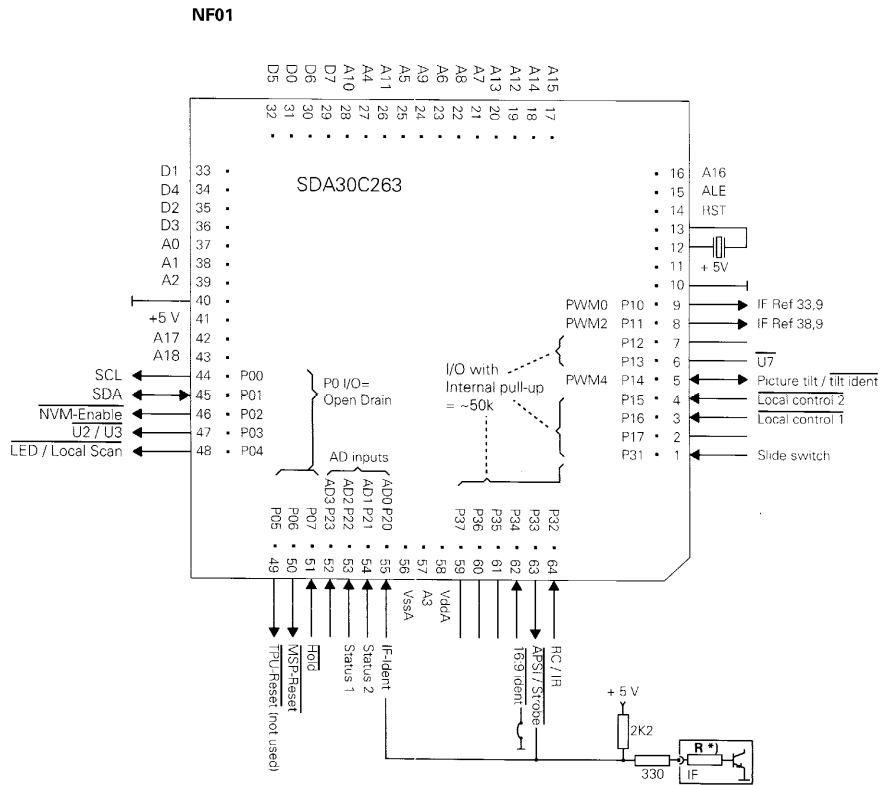
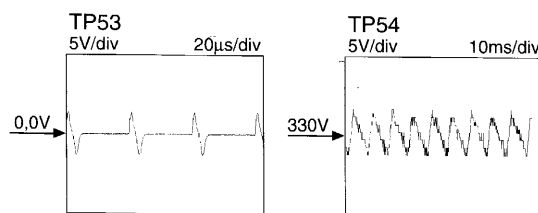
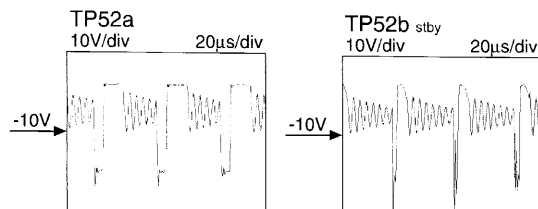
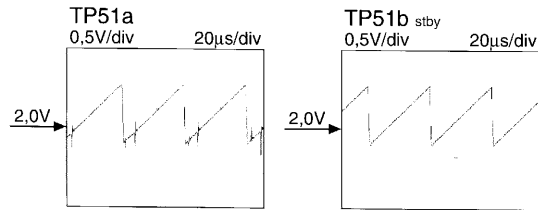
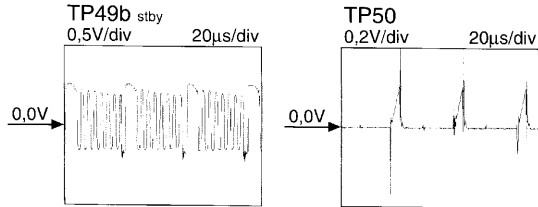
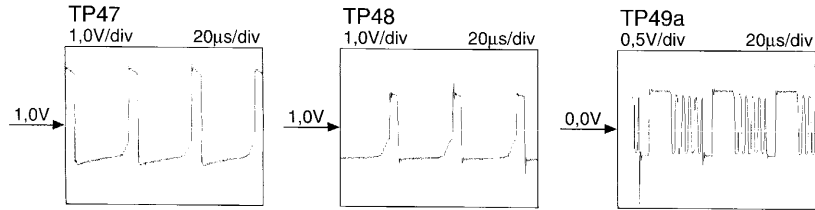
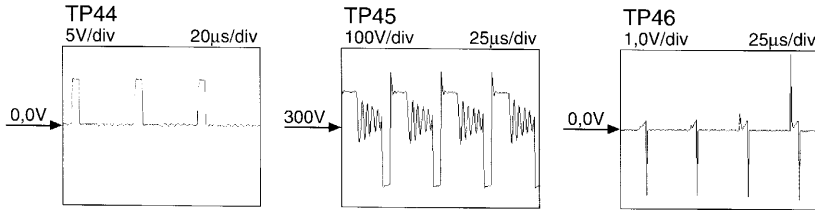
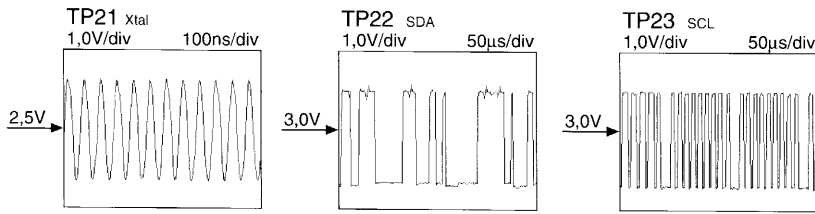

Scart status voltages			
Mode	Scart	µP-pin	
4:3	8.5...12V	3,4...5V	
16:9	3.5...8V	1,4...3,2V	
OFF	0...3V	0...1,2V	

AD0 as IF Ident			
Voltages	R *	IF versions	Frontend mod.
3,9 - 5,0	12k	BG / DK / I / LL'	SR801
3,1 - 3,9	3k9	BG / DK	SR803
2,3 - 3,1	1k5	I	SR802
1,7 - 2,3	680	BG	SR800

**3rd EDITION**  
**CHASSIS**  
**SP2-SERIE**

[www.rtv-horvat-dj.hr](http://www.rtv-horvat-dj.hr)

